

Security robot

S5.2 series, 2020 models



System for robotized patrolling • Autonomous moving by the set route • Avoiding obstacles and returning to the route • Patrolling in low-light conditions, Invisible illumination of the patrol route • Shutting down when deviating from the route • Recalling from the route in case of emergency using manual remote control mode

Intelligent video surveillance and Sounds Notification • 360-degree video surveillance • PTZ camera for two models • Human detection • H.265 compression • ONVIF Profile S • Audible warnings in robot's immediate environment • Communication intercom between the operator and people around the robot • Multi-color beacon

System with multiple robots • Uniform distribution along the patrol route • Complementary surveillance of the common areas on premises that precludes the possibility of duplication • Selecting the positions for the repeaters to support the Wi-Fi MESH network

Communications • Instant notification about events through the Security Robot Messenger • Mobile Patrol Viewer for a laptop (tablet) • Transmitting "ONVIF video" via Wi-Fi or 4G* • 4G exchange of service data and remote monitoring** • Saving routes in the cloud**

Robotized patrolling

The security robot's guidance system allows for highly-precise movement along a route set during the learning process. The robot uses visual and satellite navigation, and that is why the best precision for it to follow its route is achieved while making adjustments by using both means. For the visual navigation system to work at its full capacity, sufficient illumination is necessary. In case there is insufficient illumination, patrolling routes out in the open are to be used, in order to ensure stable operation of the GPS system.

With its highly efficient long-stroke wheel suspension, the robot can reliably traverse rough pathways, such as gravel tracks.

While patrolling, the security robot is capable of taking detours around obstacles and then getting back on its route. To move around during the night in conditions of inadequate lighting, the robot turns on infrared illumination that is invisible to the naked human eye.

In case the robot significantly deviates from its route - for example, when taking a long detour around an obstacle - the robot is equipped with an emergency shutdown system that is triggered when the robot deviates from its route by more than 5 meters. For such situations, to return the robot to its route, there is a manual remote control mode.

Group interaction and data exchange

The robots' group mode of operation supports the ability to control how robots are distributed along the patrol routes to ensure that common areas of the premises are consecutively surveyed from different observation points. It provides for uniform patrolling around the premises while minimizing the number of operating robots. It also controls the selection of the position by the repeater-robot to support the MESH network operation.

All robots are equipped with warning lights and sound notification. The voice alert is capable of repeating set phrases multiple times. There is a mode for voice communication over a built-in IP intercom between the operator and a person located near the robot. Data can be exchanged between robots, the base station, and the operator through Wi-Fi or 4G.

The operation of robots while they are on their surveillance patrol routes is supported by notifications through the Security Robot Messenger mobile messaging service. This service informs on the robots' condition, and transmits images of alarm events detected by the video analytics system to the supervisor's and security guards' telephones. To watch the video stream and see the robot's current position on the facility map, there is a specially designed software application, the Mobile Patrol Viewer. It was developed for use on an Android-powered laptop (tablet).

* if accommodating an additional router

** provided a local SIM card is installed in a conventional 4G router and payment is made for traffic

Security robot

S5.2 series, 2020 models



Four models of security robots

All security robot models have the same ability to autonomously go on surveillance patrol. There is a difference in the video surveillance system used.

There are two types of video surveillance systems available for the security robots. One video surveillance system is using on-board video analysis capability based on the built-in supercomputer. This type of security robot is able to automatically detect people that fall into the video surveillance cameras' field of view. This function is essential for patrolling when there are no people around, and when the appearance of a person on the guarded premises represents an alarm situation. In addition, these robot models have a buffer video recording mode that

guarantees reliable transmission of the alarm event video regardless of the quality of the wireless connection. The second type allows for transmitting compressed video streams from the video surveillance cameras without analyzing them, and storing them aboard the robot.

There are two kinds of design possible for both types of security robots: with a PTZ camera and without one. All robots have 6 cameras that permit 360-degree video surveillance over medium distances. To perform surveillance over long distances (more than 50 meters), the robots come equipped with a PTZ camera. During the daytime, the PTZ camera allows to observe the space around the robot over distances up to 200 meters. At night, the observation distance strongly depends on how well-lit the premises under observation are.

Smart security robot S5.2 IS Prompt

Intelligent 360-degree video surveillance and a Wi-Fi MESH repeater

A continuous 360-degree surveillance, and human detection over medium distances using an on-board intelligent video analysis system. It is ideal for patrolling along winding routes in confined spaces of medium-sized premises. Equipped with a highly-efficient Wi-Fi MESH antenna. Prompt is able to perform intelligent video surveillance tasks, and operate as a repeater to transmit data from other robots that are located outside the coverage area for the base station. Supports edge recording when working with the ONVIF VMS.

Smart security robot S5.2 PTZ IS Picard

Intelligent PTZ video surveillance and continuous panoramic video analysis

Detecting and recognizing objects at great distances using an automatically controlled PTZ camera. Continuous 360-degree panoramic image analysis, intelligent video analysis using two built-in T9 supercomputers. Perfect for robotized surveillance patrolling and video surveillance on large-sized premises that are out in the open. Provides for a high level of reliability for detecting people through a detection system that functions autonomously at different distances. Supports edge recording when working with the ONVIF VMS.



Without PTZ
Prompt

Surveillance tower



With PTZ
Picard

Security robot

S5.2 series, 2020 models



The comparative characteristics of S5.2 series security robots

Name	Prompt	Picard
Models	S5.2 IS	S5.2 PTZ IS
Quantity of panoramic cameras		6
Resolution and sensitivity of panoramic cameras	1280x720, 1.3MP; 0.005 lx	
PTZ camera optical zoom / resolution	none	x20 / 1920x1080
Sensitivity of PTZ camera	none	0.1 lux
Cameras for object detection	panoramic	panoramic and PTZ
Human detecting range at day, up to	by panoramic cameras 25 m (82 ft)	by PTZ camera 100 m (300 ft)
Face recognition range at day, up to	by panoramic cameras 2m (6 ft)	by PTZ camera 50m (150 ft)
Embedded computer for video analysis	T9	2pcs T9
Records	constantly or human detection	
Bitrate and storage size per channel	2048Kb/s or 4096 Kb/s, 0.9GB or 1.8 GB	
Embedded SSD T9	120GB	
Wi-Fi MESH and Ad Hock antennas	8dBi	2dBi
Estimated operating time	12 hours	10 hours
Charging time	4 - 6 hours	

The video analytics system of the Prompt security robot

On board the Prompt robot, the system processes images from 6 panoramic cameras. The images from these cameras are transmitted in turns to an alarm system video channel that is accessible for wireless (4G or Wi-Fi) hookup to an ONVIF CMS. When the image of a person appears on the camera display, the channel sweep is stopped, and only the image where a human being has been recognized is transmitted to the alarm system video channel. On the display, the recognized human being is highlighted with a red frame. At the same time, the Security Robot Messenger receives a photo with the human being, as well as a link to download the 10-second video fragment starting from the time the person was detected.

Even if one of the cameras reveals a person, the video analysis system continues analyzing the images from other video cameras in turns. If another camera reveals a human being, then video from that is also fed into the alarm system video channel. The corresponding message is sent to the Security Robot Messenger. All of the channels via which people are revealed are added to the alarm system's video channel. When a person disappears from the camera's field of vision, after 3 seconds that video is removed from the alarm system's video channel.

The video analytics system of the Picard security robot

Along with video analysis of images from panoramic cameras - similar to the Prompt robot - the Picard robot analyzes images from PTZ cameras, and controls their movement. The PTZ cameras scan the surrounding space using a shifting zoom, and transmit the images to a second video alarm channel that is accessible for wireless (4G or Wi-Fi) hookup to an ONVIF CMS.

If a human being or another object is revealed that is determined by using a supplemental object library (for example, an automobile), then it is highlighted by a red frame, and the photo is sent off to Security Robot Messenger, along with a link to download the relevant 10-second video fragment. At the same time, the object tracking operation mode is switched on via swiveling the PTZ camera.

When a human being is revealed, the image is analyzed to look for the person's face from a frontal position. When the front face position is found, the image is highlighted by a dark blue frame, and the photo is transmitted to the Security Robot Messenger. Control of the PTZ camera can be switched over to manual operation mode by action commands from the ONVIF CMS

Security robot



S5.2 series, 2020 models

Technical specifications

Cruising range at +5°C (41°F), up to	24 km	15 miles
Accuracy of check-point drive-through circle radius	0.8 m	2.5'
Minimum illumination for visual navigation		6 lux
Minimum illumination for obstacle avoided systems		0 lux
Speed while traveling autonomously	4 - 6 km/h	2.5 - 4 mph
Width of patrol route path, min	0.9 m	3.0'
Turning radius, min	5 m	16.4'
Ground Clearance	14 cm	5.5"
Climbing Angle		15°
Dimension	1420 x 780 x 1320mm	56" x 31" x 52"
Weight (without batteries)	125 kg	275 lb
Delivered weight	Air Freight Packing 185 kg, 408 lb; sea packing 195 kg, 430 lb	
Waterproof and dustproof level		IP65
Operating temperature range	-25°C ... +55°C	-13°F ... 131°F
Storage temperature range	-40°C ... +70°C	-40°F ... 158°F
Acoustic noise		64dB (A)

Body and Chassis

Body	Fiberglass
Frame	Aluminum alloy, Hard Anodizing
Tires	145/75 R8

Vehicle Power

Drive System	Rear differential drive
Motor drive	24 Volts DC 500W
Brake System	Electromagnetic
Accumulate battery	2 x 12.6V 120A/h Lead Acid
Battery Charger	48 Volt DC/ 110-250VAC, 600W, UL/CSA, off board
Charging time	4 hours in fast mode or 6 hours in normal mode

Interface

Wireless	4G, Wi-Fi, Wi-Fi Ad Hock, Bluetooth
Audio	IP Intercom, Audio file playback
Visual	Color Beacon and Alarm Button
Remote Control	915 MHz or 434.05-434.75 MHz, ISM band

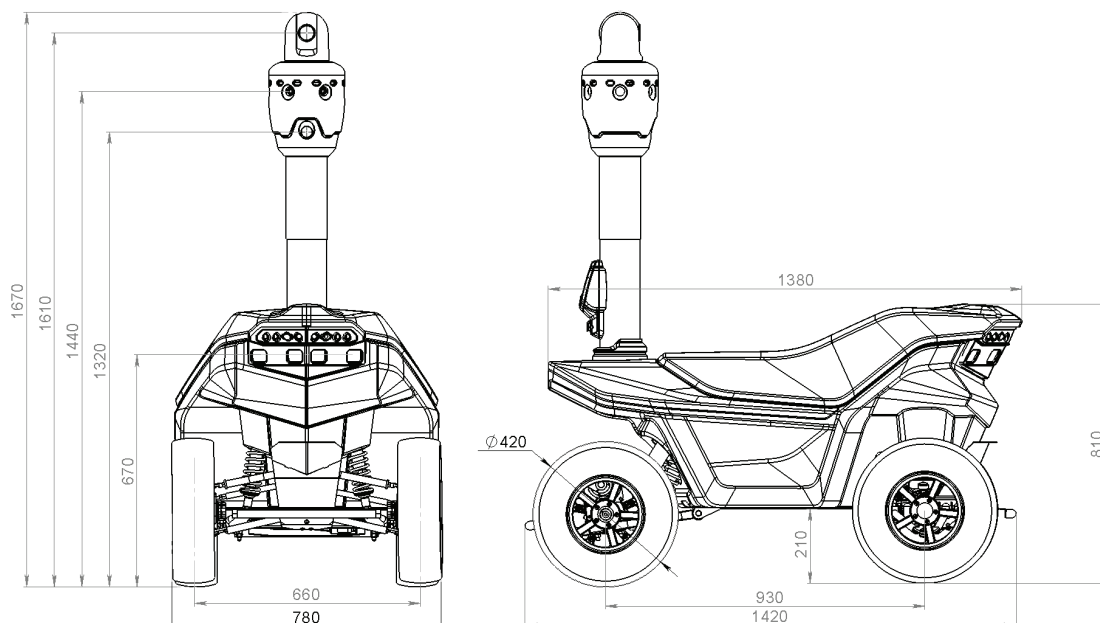

SMP Robotics Systems Corp.,

One Harbor Drive, Suite 300 Sausalito, CA 94965, USA

<https://smprobotics.com>; info@smprobotics.com, +1 415 572 2316, +1 702 666 9146 (Fax)